

LARGE JOURNAL COVER

INSTRUCTIONS

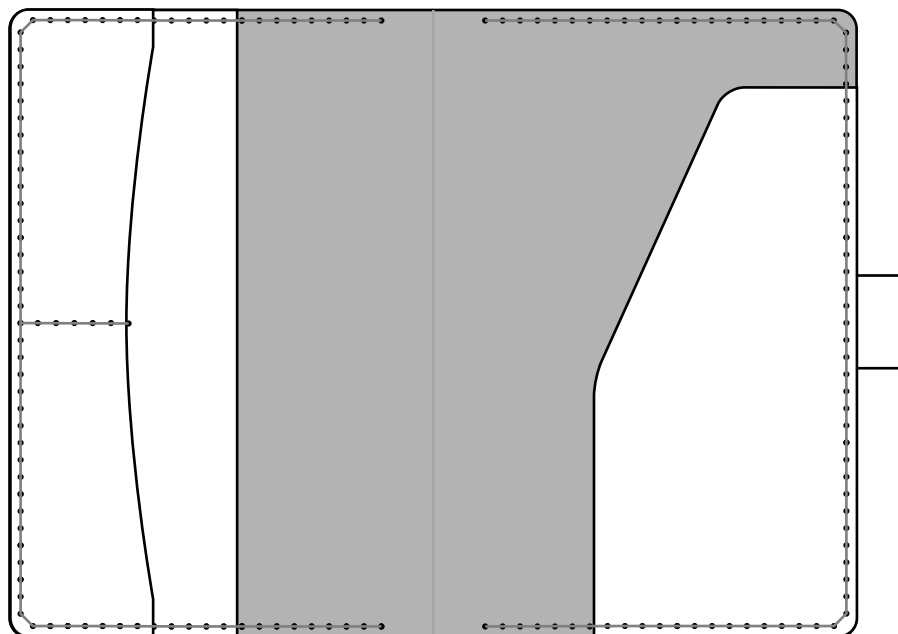

BUCKLEGUY

LEATHERCRAFT SUPPLY

STITCHING AND BURNISHING SUPPLIES

- + NEEDLES
- + THREAD:
 - A. LEFT SIDE AND RIGHT SIDE SEAM (x2) 60"
 - B. CARD POCKET FRONT AND BACK (x1) 15"
- + CANVAS
- + SANDPAPER
- + BEESWAX

LEATHER

1. FRONT PANEL
2. CARD POCKET BACK
3. CARD POCKET FRONT
4. NOTEBOOK POCKET
5. (OPTIONAL) PEN HOLDER

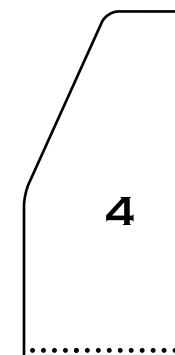
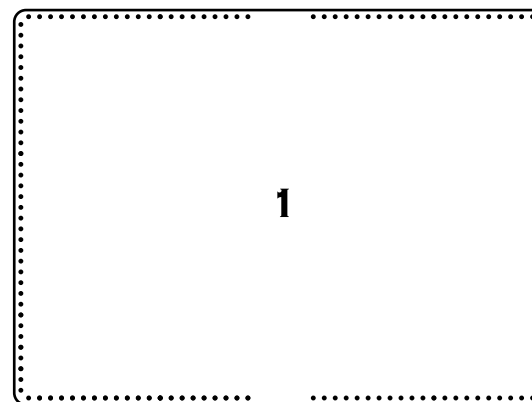
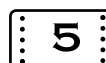
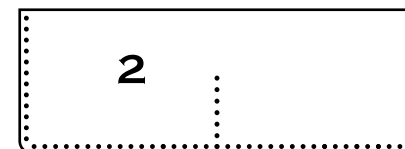
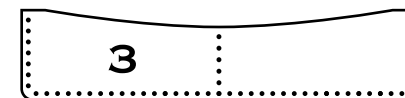



YOU SHOULD KNOW



PAPER BINDER CLIPS ARE PERFECT FOR HOLDING LAYERS OF LEATHER TOGETHER WHILE YOU STITCH. THEY SERVE THE PURPOSE OF SEWING PINS.

ALL STITCHING START POINTS ARE MARKED WITH A STAR.



FLESH VS. GRAIN COLORATION

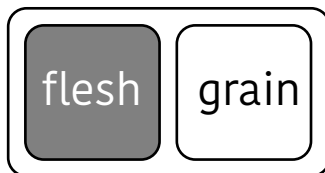

STEP 1: (Optional) Burnish everywhere marked by the grey lines below:

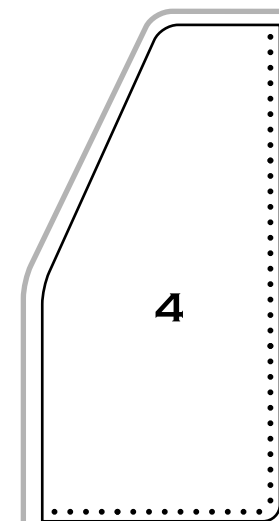
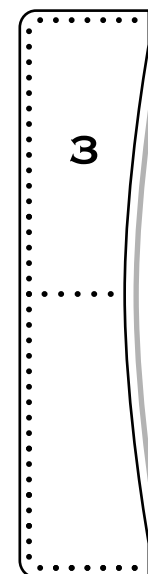
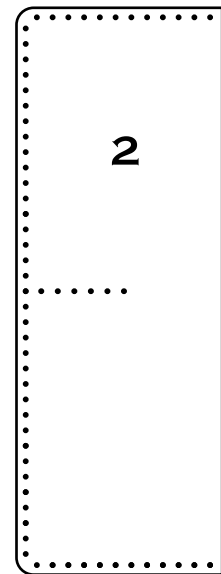

STEP 2: Stitch the card pocket front (3) onto the card pocket back (2). Lay the card pocket front (3) onto the card pocket back (2) flesh side to grain side. The first seam that needs to be stitched is the 5 hole seam that is perpendicular to the long left side seams of these two pieces. Prepare your needles. Start with the needle in the farthest right hole, and saddle stitch to the left, until you reach the last hole along this seam. Back stitch, pull both needles through to the flesh side of the card pocket back (2), snip and carefully burn threads.

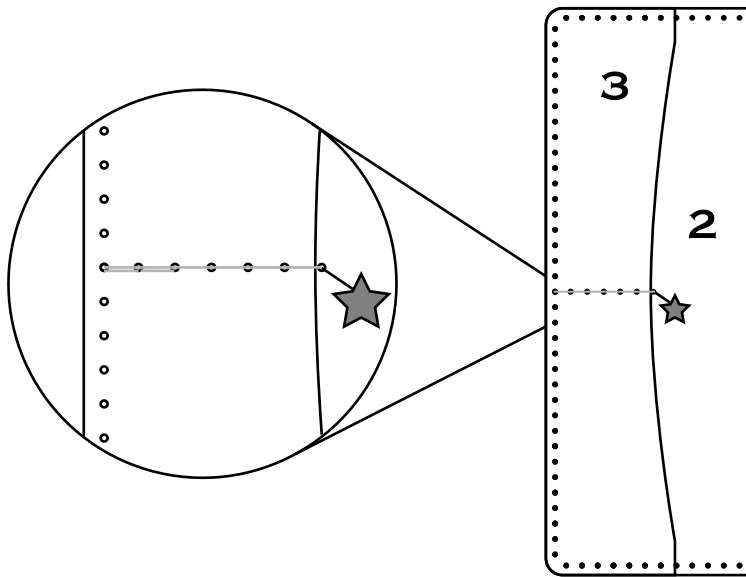

BUCKLEGUY

LEATHERCRAFT SUPPLY

STEP 3: Stitch the assembled card pockets (2, 3) onto the front panel (1). Prepare your needles. Lay the front panel (1) in front of you, flesh side up. Place the assembled card pocket (2, 3) onto the left side of the front panel, grain side up. Binder clips are helpful in this stage. Start with your needle at the top of the front panel (1) along the left side seam. Saddle stitch to the left, along this top seam, making sure to attach the top seam of the card back pocket (2) and then the card pocket front (3). Continue to saddle stitch down the left side seams, and all the way around the bottom seam. When you reach the last hole, back stitch. Pull both needles through to the flesh side of the front panel (1). Snip and carefully burn threads.

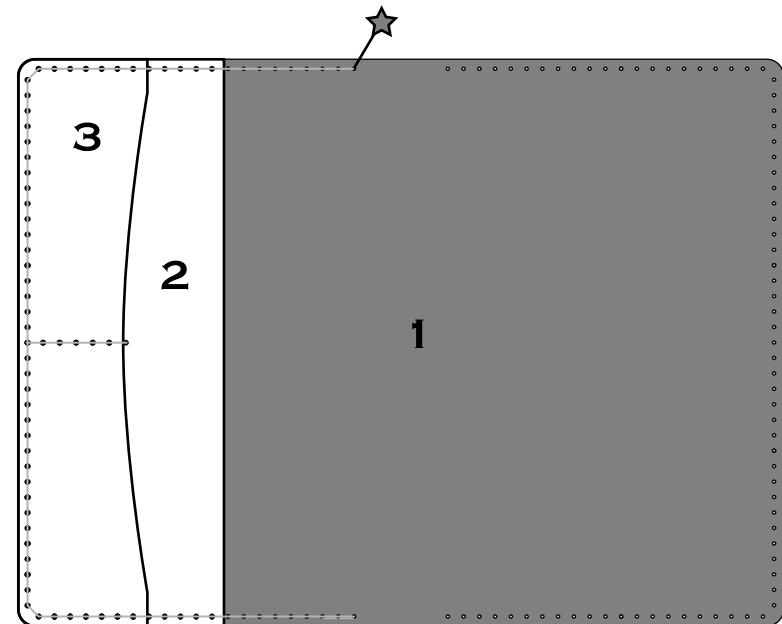

STEP 4: Stitch the notebook pocket (4) and the pen holder (5) onto the right side of the front panel (1). Prepare your needles. Line up the bottom right corner of the notebook pocket (4) with the bottom right corner of the front panel (1) flesh sides together. Start with your needle in the top of the front panel (1) along the right side seam. Saddle stitch to the right, and down the right side of the front panel (1), making sure to add in the notebook pocket (4) at the correct stitching hole. When you get about halfway down the right side seam (about 15 holes down from the top) it is time to attach the optional pen holder (5), this is a good time to use the binder clip to hold the pen holder (5) in place. Fold the pen holder (5) in half, lining up the stitching holes, and creating a tube for a pen. Place the folded pen holder (5) along the seam of the notebook pocket (4) and the front panel (1), making sure to send the needle through all four layers. Stitch on the pen holder (5) completely, and continue to stitch all the way down the right side seam of the notebook pocket (4) and the front panel (1), and to the left along the bottom seams. When you reach the last hole, back stitch. Pull both needles through to the flesh side of the front panel (1). Snip and carefully burn threads.

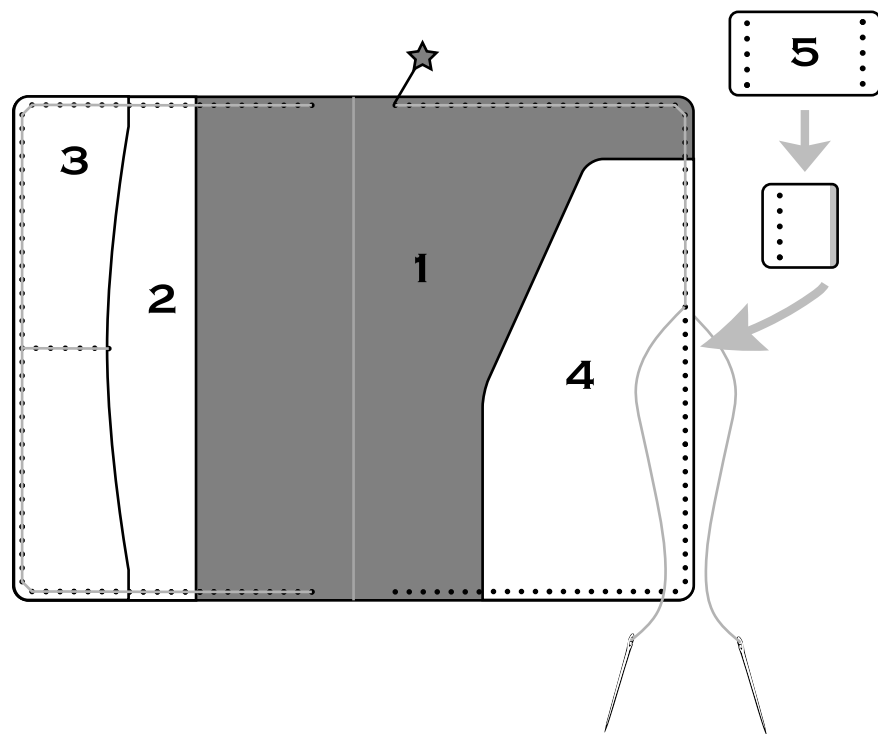

BUCKLEGUY

LEATHERCRAFT SUPPLY

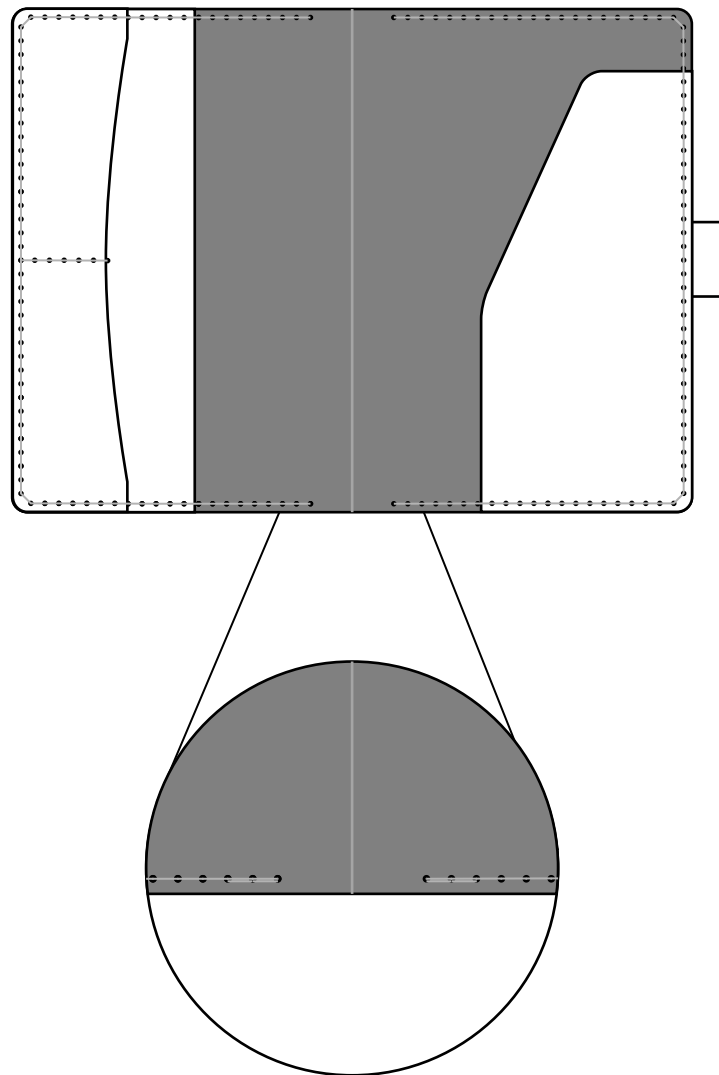

STEP 5: (Optional) Sand and burnish outer edge marked by the grey line below Note, on the parts of the perimeter that are made up of only one layer of leather, do not sand and be sure to burnish more lightly.

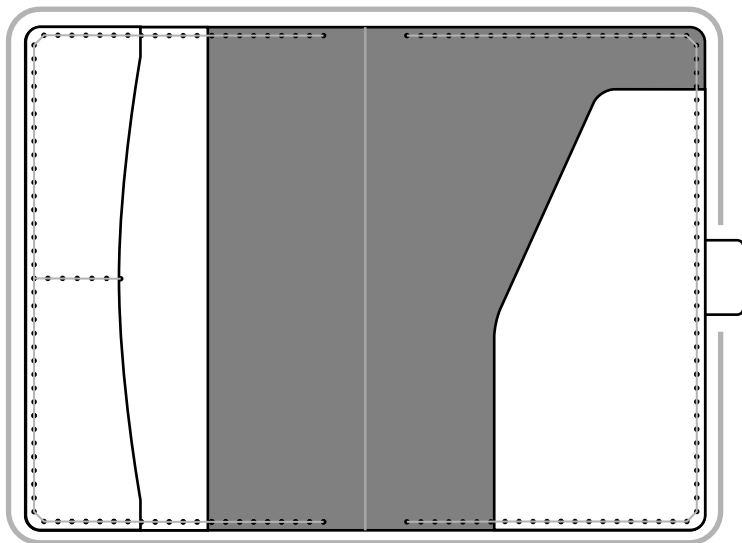

BUCKLEGUY

LEATHERCRAFT SUPPLY

ALL DONE! ENJOY
YOUR NEW JOURNAL
COVER!

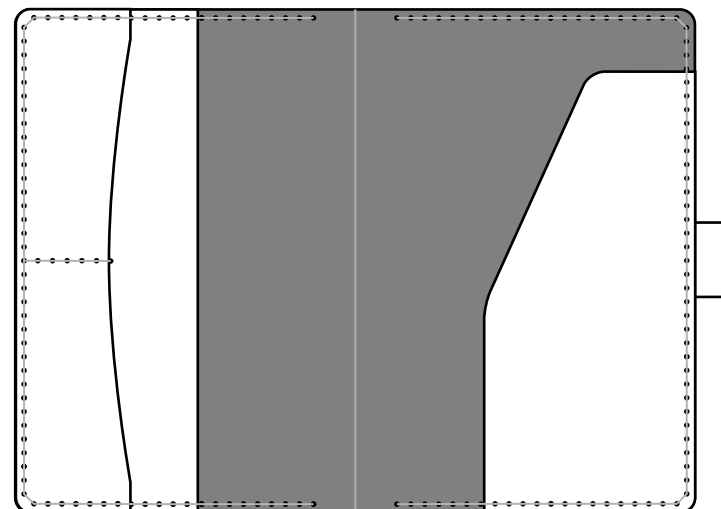

 @BUCKLEGUYCOM

THANKS FROM ALL OF US AT BUCKLEGUY!

 @BUCKLEGUY

SHARE YOUR PROJECTS WITH US ON
SOCIAL MEDIA

 @BUCKLEGUY

BY USING THE HASHTAG #BGKITS

 @BUCKLEGUY.COM