

5-POCKET BIFOLD

INSTRUCTIONS

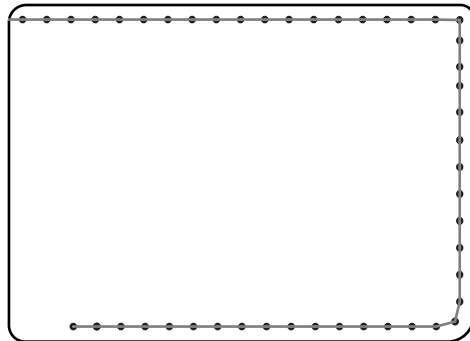
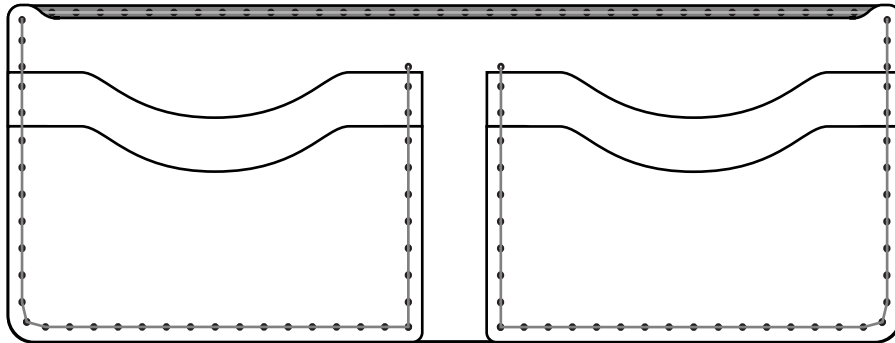

BUCKLEGUY

LEATHERCRAFT SUPPLY

STITCHING AND BURNISHING SUPPLIES

+NEEDLES

+THREAD(S):

A. T-POCKETS AND INNER SEAMS (x4) 16"

B. TOP OF FRONT (x1) 38"

C. FRONT SEAMS (x2) 42"

+CANVAS

+SANDPAPER

+BEESWAX

LEATHER

1. FRONT

2. BACK

3. T-POCKETS (x2)

4. LEFT POCKET

5. RIGHT POCKET

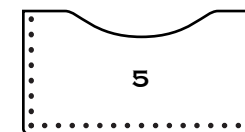
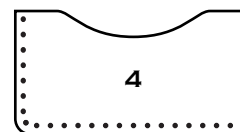
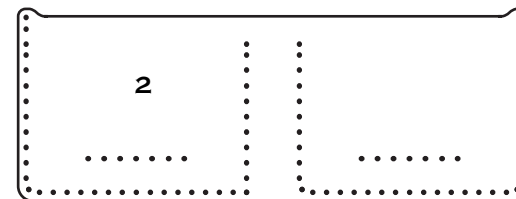
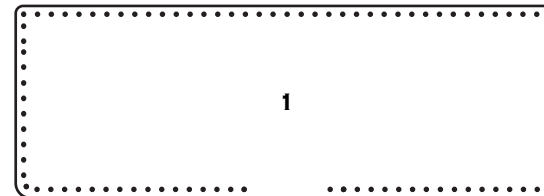



YOU SHOULD KNOW

PAPER BINDER CLIPS ARE PERFECT FOR HOLDING LAYERS OF LEATHER TOGETHER WHILE YOU STITCH. THEY SERVE THE PURPOSE OF SEWING PINS.

ALL STITCHING START POINTS ARE MARKED WITH A STAR.



FLESH VS. GRAIN COLORATION



STEP 1: (Optional) Burnish the tops and sides of the T-pockets (3), the tops and the straight side of the right pocket (5) and left pocket (4), the top of the back (2), and the top of the front (1) marked by the grey lines below:

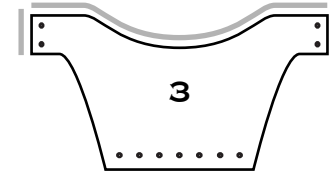
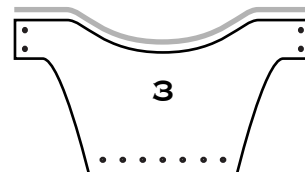
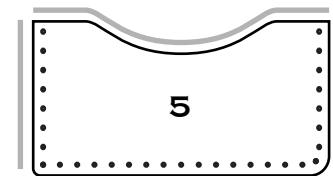
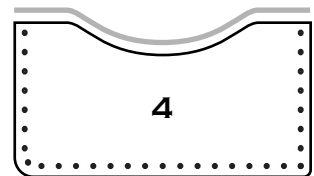
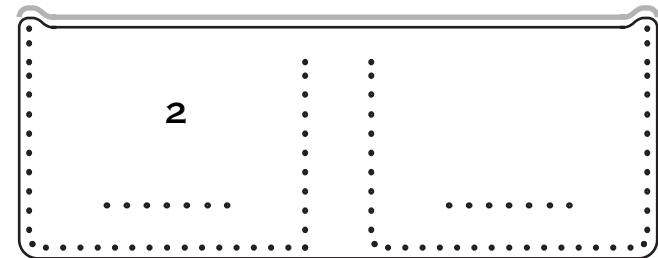
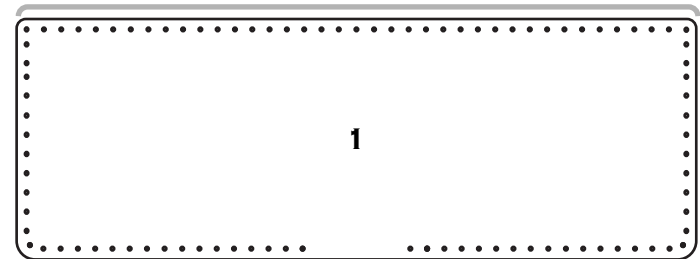

STEP 2: Saddle Stitch along the top of the front (1). Prepare your needles. Starting with your needle in the farthest left stitching hole, saddle stitch just along the top seam of the front (1). When you reach the last stitching hole on the right, back stitch. Pull both needles through to the flesh side of the front (1). Snip and carefully burn threads.

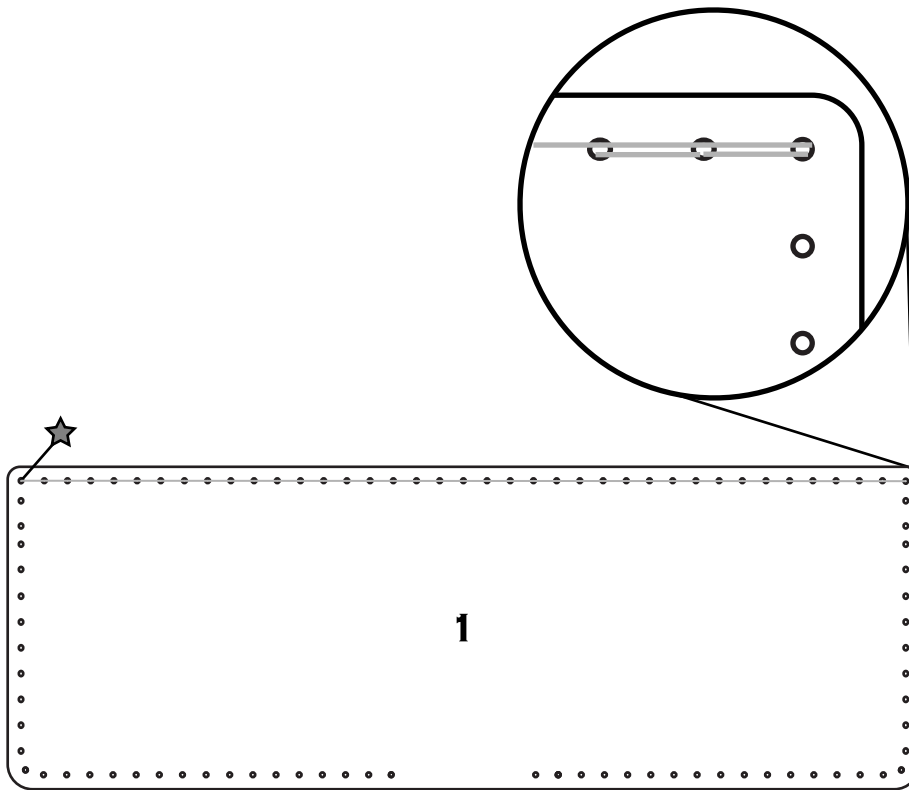

STEP 3: Saddle stitch the 7 hole bottom seam of one T-pocket (3) onto the left side of the back (2). Prepare your needles. Lay one T-pocket (3) onto the left side of the back (2) flesh side to grain side, lining up the seven holes at the bottom of the T-pocket (4) to the seven holes on the back (2). Begin your saddle stitch by threading the needle through the farthest left hole. Saddle stitch the T-pocket (3) onto the back (2) until you reach the farthest hole on the right. Back stitch and pull both needles through to the grain side of the T-pocket (4). Snip and carefully burn threads. ** tip: using a heavy object, flatten down these stitches **

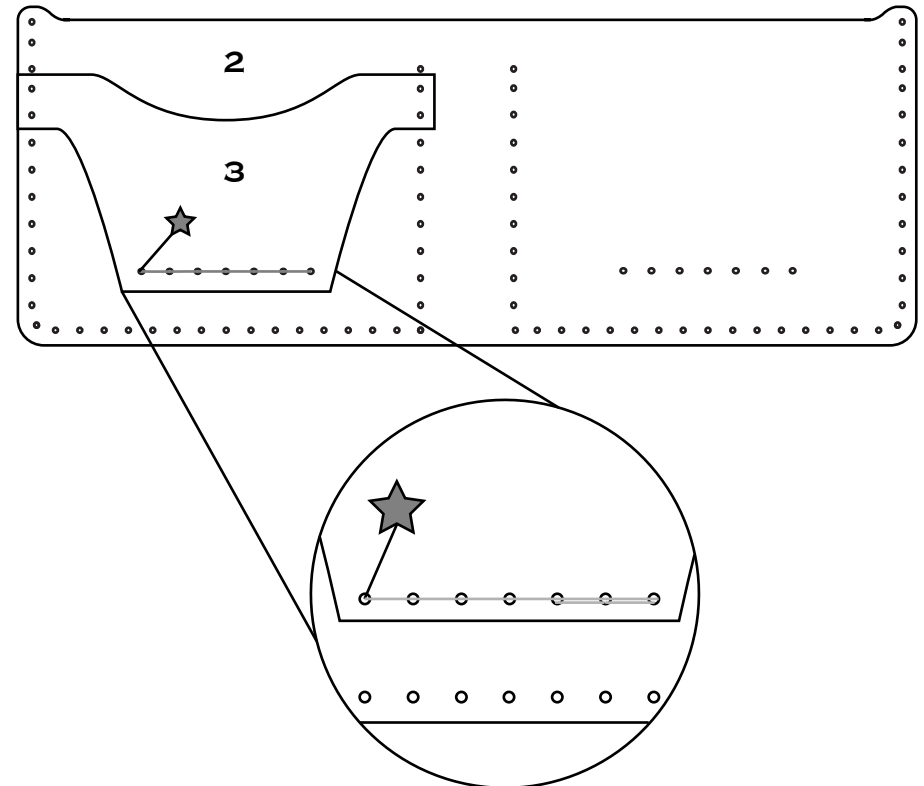

STEP 4: Saddle stitch the 7 hole bottom seam of the second T-pocket (3) onto the right side of the back (2). Repeat the same process from step 3, stitching the T-pocket (3) onto the right side of the back (2). Back stitch and pull both needles though to the grain side of the T-pocket (4). Snip and carefully bun threads. ** tip: using a heavy object like a hammer, flatten down these stitches **

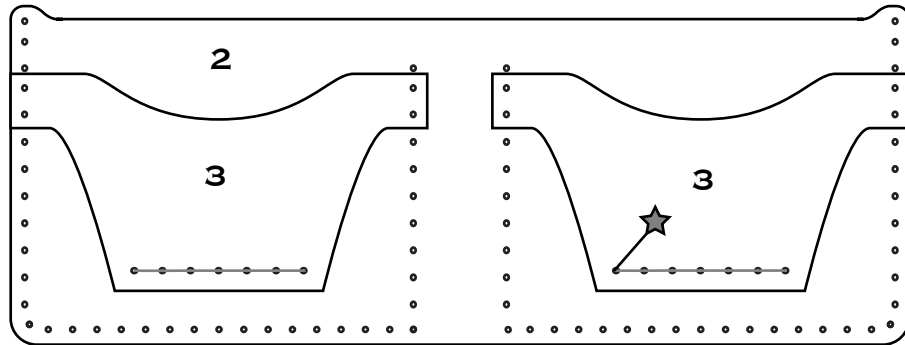

STEP 5: Saddle stitch the left pocket (4) and the left T-pocket (3) onto the left side of the back (2). Prepare your needles. Lay the left pocket (4) over the stitched T-pocket (3) on the left side. Binder clips are helpful at this point. Begin with your needle in the top hole of the right side seam on the left side of the back (2). As you bring the needle into the next hole, you are attaching the T-pocket (3) onto the back (2). Keep saddle stitching on the T-pocket (3), and add in the left pocket (4). Saddle stitch the right side of the left pocket (4). When you reach the bottom hole of this seam, back stitch. Pull both needles through to the flesh side of the back (2), snip, and carefully burn threads.

STEP 5 CONTINUED:

BUCKLEGUY

LEATHERCRAFT SUPPLY

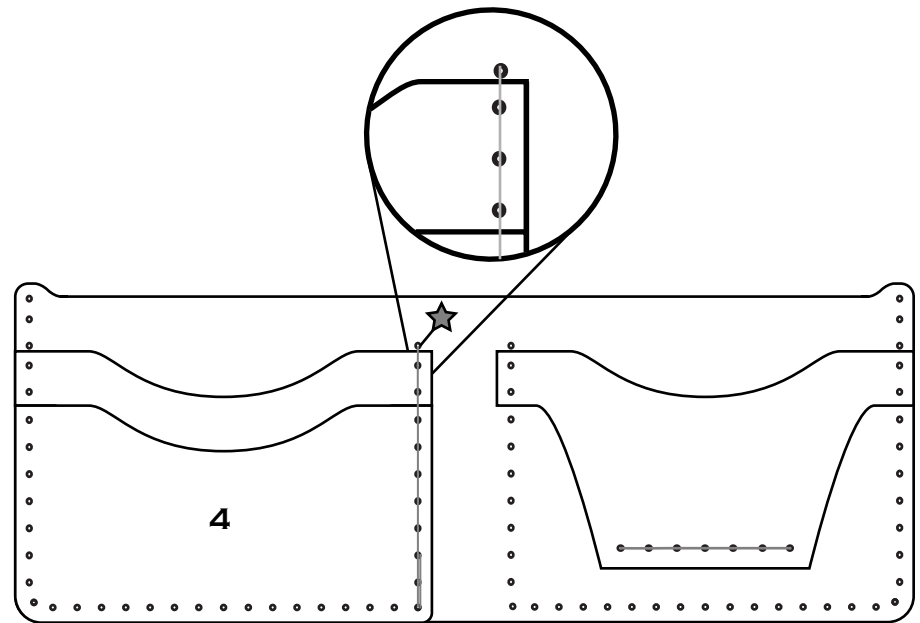

STEP 6: Saddle stitch the right pocket (5) and the right T-pocket (3) onto the right side of the back (2). Prepare your needles. Lay the right pocket (5) over the stitched T-pocket (3) on the right side of the back (2). Binder clips are helpful at this point. This process is the same as in step 5, except we are saddle stitching along the left side seam of the right pocket (5). When you reach the bottom hole of this seam, back stitch. Pull both needles through to the flesh side of the back (2), snip, and carefully burn threads.

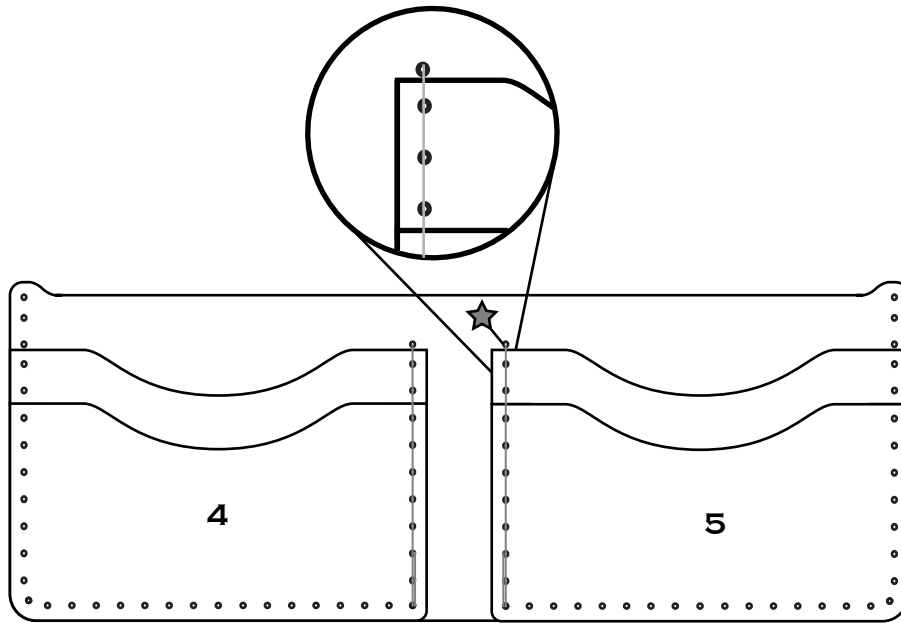

STEP 8: Saddle stitch the left side of the back (2) onto the front (1) flesh sides together. Prepare your needles. Start your needles in the top left hole of the left pocket (4). Pull this needle through the back (2) and into the corresponding hole of the front (1). Begin to saddle stitch to the left, securing the side seam of the left side of the back (2) to the front (1). Continue to stitch down and across to the right, securing the left bottom of the back (2) to the front (1). When you reach the last hole that meets the previous stitches, back stitch twice. Pull both needles through to the grain side of the back (2). Carefully snip and burn threads.

STEP 7: Crease the outer (1). Fold the entire outer (1) in half like a book. Line up the two corners of the left side to the two corners on the right side. Using your thumb, press down along the “spine” to give your bifold its fold.

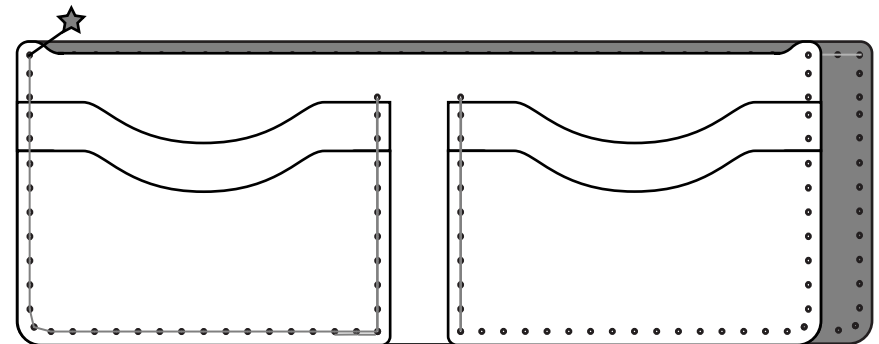
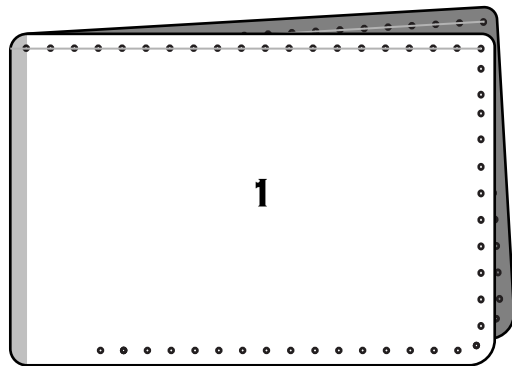

STEP 9: Saddle stitch the right side of the back (2) onto the front (1) flesh sides together. Prepare your needles. Start your needles in the top right of the right pocket (5). Pull this needle through the back (2) and into the corresponding hole of the front (1). Begin to saddle stitch down the right side, securing the seam of the right side of the back (2) to the front (1). Continue to stitch down and across to the bottom securing the back (2) to the front (1). When you reach the last hole that meets the previous stitching, back stitch twice. Pull both needles through to the grain side of the back (2). Carefully snip and burn threads.

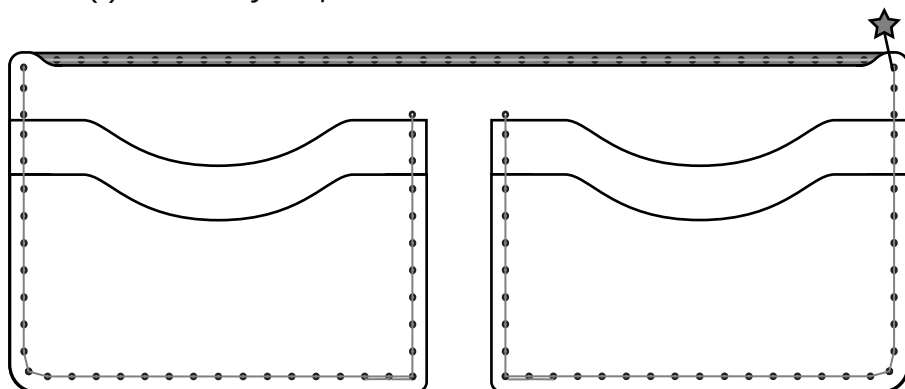

STEP 10: (Optional) Burnish all stitched edges of wallet marked by the grey line below.

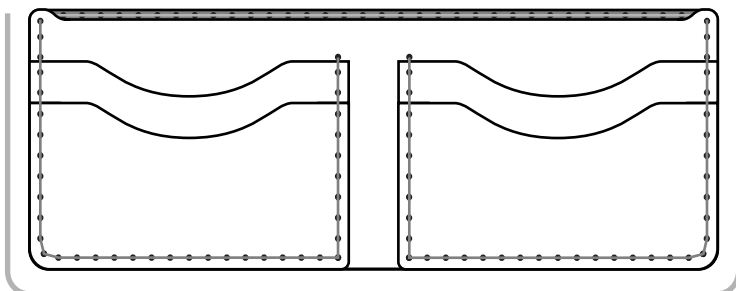

BUCKLEGUY

LEATHERCRAFT SUPPLY

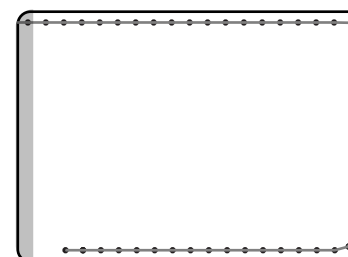
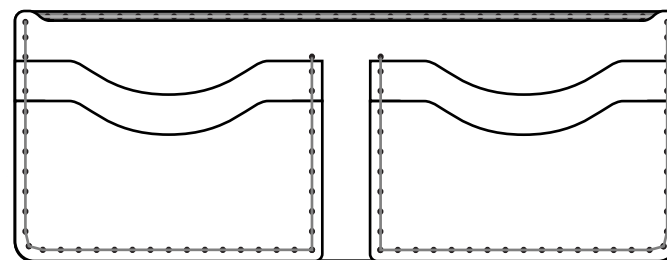

ALL DONE! ENJOY
YOUR NEW WALLET!

THANKS FROM ALL OF US AT BUCKLEGUY!

SHARE YOUR PROJECTS WITH US ON
SOCIAL MEDIA

BY USING THE HASHTAG #BGKITS

